

10.2. Installation Dimensions

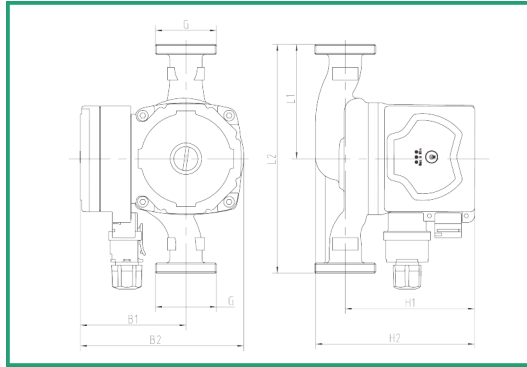

Power (W)	Product Model	Material of Pump Body				Dimension (mm)						
		Cast Iron	Plastic	Copper	SS	L1	L2	B1	B2	H1	H2	G
45	APUMPHE	●	●	●		65	130	82	130	103	130	1 1/2"

11. Trouble-Shooting Schedule



Warning

Before conducting any maintenance and repair of the motor pump, ensure that power supply has been cut off and will not be connected accidentally.

Symptom	Control Panel	Cause	Corrective Action
Motor pump cannot be started	Indication lamp 'Off'	Equipment fuse blown	Replace the fuse
		The circuit breaker of Current control or voltage control opens	Connect the circuit breaker
		Failure of pump motor	Return to factory maintenance
	Blink 1 time	High voltage	Check whether power supply is in specified range
	Blink 2 times	Under voltage	Check whether power supply is in specified range
	Blink 3 times	PCB component failure or Motor failure	Return to factory maintenance
	Blink 4 times	Missing phase protection	Return to factory maintenance
	Blink 5 times	Rotor blocked	Remove the pump housing and clean the rotor
Blink 6 times	No water in pump	Open the valve & supply water to the pump	



APUMPHE

Smart Band A Circulating Pump



Installation and Operation Manual

Notes:

1. Read the installation manual carefully before installation and use.
2. The manufacturer will not be liable for any personal injury, pump damage and other property damage due to failure to comply with safety warnings.
3. The installers and operators must comply with local safety regulations.
4. The user must confirm that only qualified personnel with professional certification and proficiency of this manual are permitted to install and maintain this product.
5. The pump is rated IP44 and must not be installed in a place that is damp or may be splashed by water.
6. For convenient access of maintenance, a shut-off valve shall be installed on each side of the pump.
7. The power supply of the pump must be disconnected before installation and maintenance.
8. For domestic hot water, copper or stainless steel pump body shall be used.
9. In hard water areas use appropriate water treatment additives to prevent calcium deposits, which can block pipelines and / or the pump impeller.
10. Do not start the pump without liquid.
11. Some models are not suitable for drinking water.
12. The liquid may be high-temperature and high-pressure; therefore, the liquid in the system must be completely drained or the shut-off valves on both sides must be closed before moving and dismantling the pump to prevent a burn hazard.
13. If removing the exhaust bolt, high-temperature and high-pressure liquid will be released. Measures must be taken to safely contain any released liquid.
14. Ventilation must be ensured in summer or high ambient temperature conditions to avoid condensation that may cause electrical malfunctions.
15. If there is a risk of frost damage, install a frost protection thermostat, or drain down the system in order to avoid frost damage to the pump body.
16. If the pump is left unused for a long time, please close the pipe valve in the inlet and outlet of the pump and disconnect the power supply.
17. If the flexible cord of cable is damaged, it must be replaced by a qualified person.
18. Please close the valve at the inlet of the pump and disconnect power of the pump immediately if overheating or abnormality of motor is detected, and contact your vendor or service centre.
19. If problem cannot be addressed according to the manual, please close the valves on the inlet and outlet of the pump immediately, cut off power supply and contact your vendor or service centre immediately.
20. This product shall be put in a place out of reach of children. After installation, take an isolation measures to avoid access of children.
21. This product shall be stored in a dry, well ventilated and cool place under room temperature.



Warning

Failure to comply with this safety instruction may lead to personal injury

Caution

Failure to comply with this safety instruction may lead to equipment malfunction or damage

Note

Note or instruction for easy and safe operations.

10. Technical Parameters and Installation Dimensions

10.1. Technical Parameters

Power Supply Voltage	220V-240V, 50/60Hz, PE	
Motor Protection	The pump needs no external protection	
Degree of Protection	IP 44	
Insulation Class	H	
Relative Humidity	Maximum 95%	
System Load Bearing	1.0 MPa	
	Liquid Temperature	Minimum Inlet Pressure
	≤+85°C	0.005 MPa
	≤+90°C	0.028 MPa
Suction Port Pressure	≤+110°C	0.100 MPa
EMC Standard	EN61000-3-2 and EN61000-3-3 / EN55014-1 and EN55014-2	
Sound Pressure Class	The sound pressure level of pump is lower than 42dB (A)	
Ambient Temperature	0°C to +40°C	
Temperature Grade	TF110	
Surface Temperature	The maximum surface temperature is not higher than +125°C	
Liquid Temperature	+2°C to +110°C	

To prevent condensation in the junction box and rotor, the temperature of pumping liquid of the motor pump must be always higher than the ambient temperature.

For domestic hot water, it is suggested that water temperature should remain below 65°C to reduce scaling.

Ambient Temperature (°C)	Liquid Temperature	
	Minimum (°C)	Maximum (°C)
0	2	110
10	10	110
20	20	110
30	30	110
35	35	90
40	40	70

9. Features

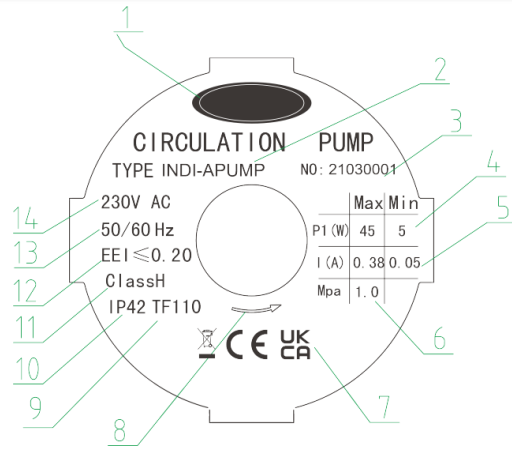

No	Descriptions	
1	Company Name (brand) <i>*if applicable</i>	
2	Pump Type	
3	Number	Date of manufacture: the first six numbers
		Serial number: the last four numbers
4	Power (Watt)	Minimum power input in minimum pattern
		Minimum power input in maximum pattern
5	Electricity (ampere)	Minimum flow in minimum pattern
		Minimum flow in maximum pattern
6	Maximum system load bearing (Mpa)	
7	Certification Mark	
8	Rotation direction	
9	Highest Liquid Temperature	
10	Protection Grade	
11	Insulation Class	
12	Energy Index	
13	Frequency (Hz)	
14	Voltage (V)	

1. General

1.1. The APUMPHE circulation pump is designed for use in domestic heating and hot water systems.

The product is most applicable to the following systems;

- Stable and variable-flow heat supply systems
- Variable-temperature pipeline heat supply system
- Heat supply system with night mode
- HVAC system
- Industrial circulation system
- Domestic heating and domestic water supply system

This pump is equipped with a permanent magnet motor and differential pressure controller, capable of automatically & continuously adjusting motor performance to meet the actual needs of the system.

The pump is equipped with a control panel on the front for easy operation by users.

2.2. Advantages

Easy installation and start-up

Provided with self adaptive mode

AUTO

(Initial setting). In most cases, the motor pump needs no adjustment and can be readily started and will adjust automatically to meet the actual needs of the systems.

High-degree comfort

Low operational noise of motor pump and whole system.

2. Operating Conditions

2.1. Ambient Temperature

Ambient temperature: 0°C to + 40°C

2.2. Relative humidity (RH)

Maximum humidity: 95%

2.3. Medium (liquid delivery) temperature

Liquid delivery temperature: +2°C to +110°C

To avoid condensation in control box and the stator, the temperature of liquid pumped by the motor pump must always be higher than the ambient temperature.

2.4. System Pressure

Maximum system pressure: 1.0MPa (10bar)

2.5. Degree of Protection

IP44

2.6. Inlet Pressure

Liquid Temperature	<85°C	90°C	110°C
Inlet Pressure	0.05bar	0.28bar	1bar
	0.5m head	2.8m head	10m head

2. Operating Conditions

2.7. Pumping Liquid

The pumping liquid includes thin, clean, non-corrosive and non-explosive liquid which shall not contain any solid particles, fibre or mineral oil, and the pump must definitely not be used to pump inflammable liquid such as rapeseed oil and gasoline. If the pump is used in a place with relatively high viscosity, the pump has lower performance. So when choosing a pump, the viscosity of liquid must be taken into account.

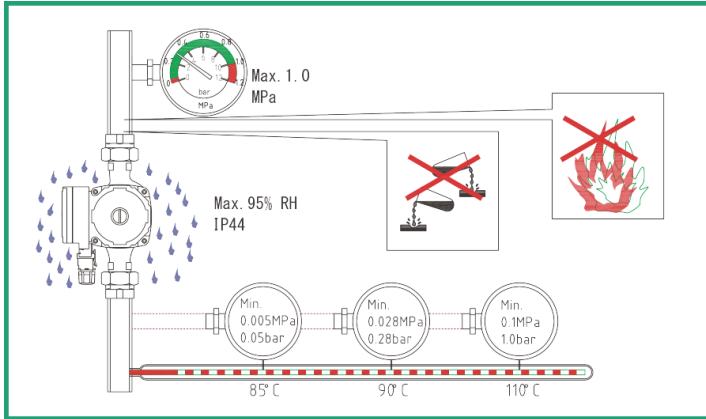

3. Installation

3.1. Installation

When installing APUMPHE series circulation pump, the arrow on the motor pump case indicates the flow director of liquid through the pump.

When installing the motor pump in the pipeline, the two gaskets supplied must be installed at the inlet and outlet

During the installation, the motor pump shaft must be horizontal.

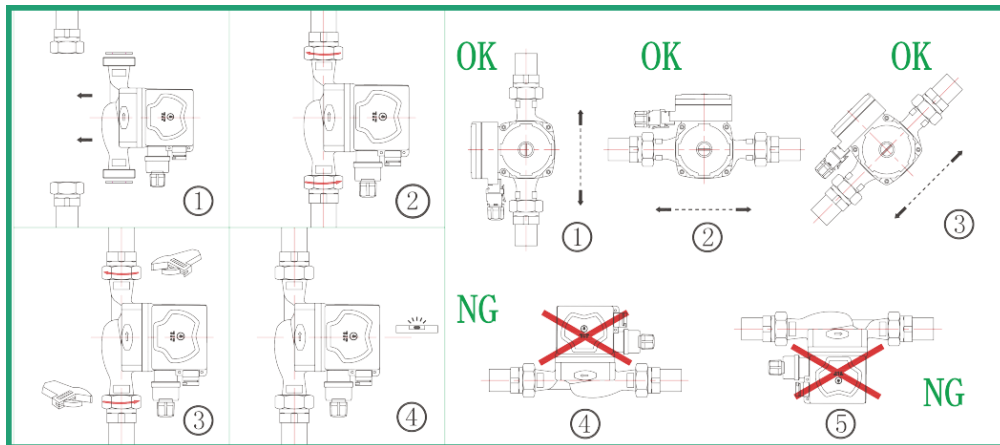

8. Performance Curve

8.1. Guide on Performance Curve

Every setting of the motor pump has corresponding performance curve (Q/H curve). However AUTO (Self Adaptive Mode) mode covers just one performance curve.

The input power curve (P1 curve) belongs to every Q/H curve. Power curve represents the power consumption of motor pump in given Q/H curve with Watt as the unit.

P1 value corresponds to the readings taken from the monitor of motor pump.

8.2. Curve Conditions

The followings are applicable to the performance specified in the APUMPHE series manual:

- Test liquid: air-free water
- Applicable density of curve $\rho=983.2 \text{ Kg/m}^3$, and liquid temperature $+60^\circ\text{C}$.
- All curves represent averaged value, and shall not be used as guarantee curve. If a specific performance is needed, then separate measuring shall be conducted.
- Velocity Max, Min curves have all been marked
- The applicable Kinetic viscosity of the curve, $u=0.474\text{mm}^2/\text{s}$ (0.474CcST)

8.3. Performance Curve

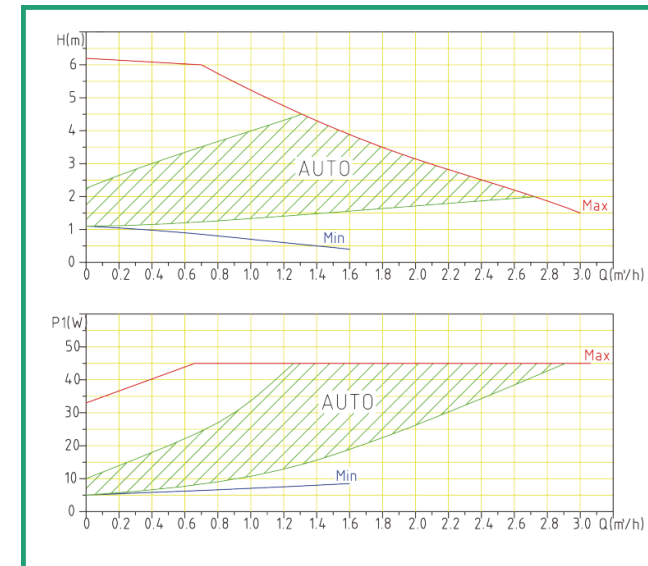

6. Motor Pump Setting

6.1. Motor pump setting based on System Type

Initial setting = AUTO (Self-adaptive mode)

Recommended and available pump setting

- AUTO (Self Adaptive mode) can adjust the performance of motor pump based on the actual head demand of the system. Self adaptive mode adjusts over time to find the most effective setting, so before changing the motor pump setting, maintain AUTO (Self adaptive mode) setting for at least one week.
- If you select to change back to AUTO mode, the APUMPHE motor pump can memorise its last setting in AUTO mode and continue adjusting the performance automatically.
- It may take several minutes or even hours to reach the optimal operation mode after motor pump setting is changed from the optimal setting (the "Recommended above mention") to one of the other optional setting. If the optimal setting of motor pump fails to enable each room to obtain desired heat distribution then you should change the motor pump setting to other settings.
- Please refer to Section 7.1 for the relations between pump setting and performance curve.

7. Motor Pump Setting and Performance

7.1. Relations between Pump Setting and Performance

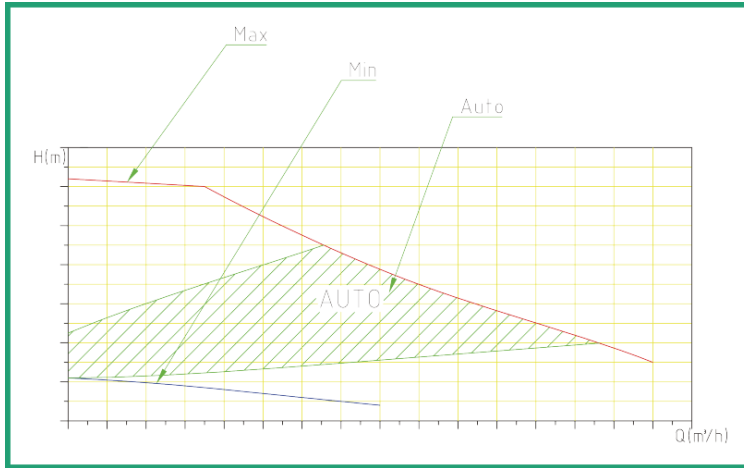

Setting	Pump Characteristics	Functions
AUTO (initial setting)	Highest to Lowest Proportional Pressure Curve	AUTO function will automatically control the pump performance within the specified scope; Adjust pump performance based on system scale; Adjust pump performance based on load variance within a period of time; Under the AUTO mode, the pump will be set to proportional pressure control
Max	Velocity Max	It runs on the constant curve in a constant velocity. In the velocity Max mode, the pump is set to work on the highest curve under all working conditions.
Min	Velocity Min	It runs on the constant curve in a constant velocity. In the velocity Min mode, the pump is set to work on the lowest curve under all working conditions.

3.2. Position of Junction Box

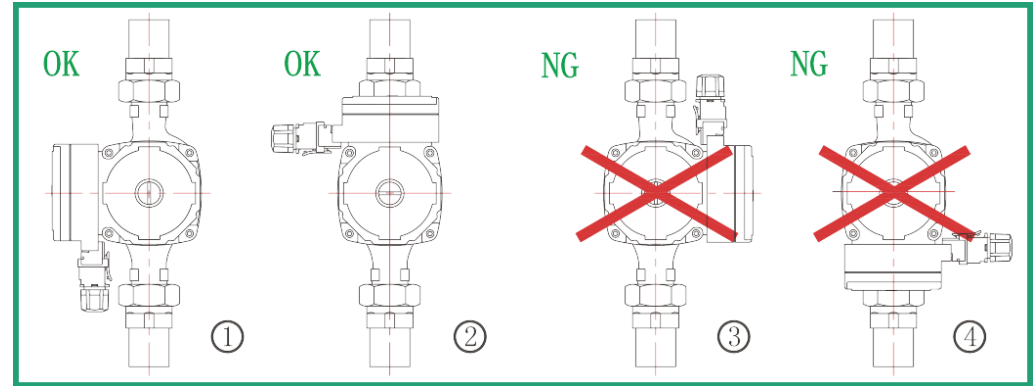

3.3. Changing Position of Junction Box

The junction box can be rotated in a step of 90°.

The procedures for changing the position of junction box are as follows;

- Close the valves at the inlet and outlet and release the pressure.
- Unscrew and remove the four socket head screws that fasten the pump body.
- Rotate the motor to the required position and align the four screw holes.
- Install the four socket head screws again and fasten them clockwise making sure they are fully tightened.
- Open the valves at the inlet and outlet.

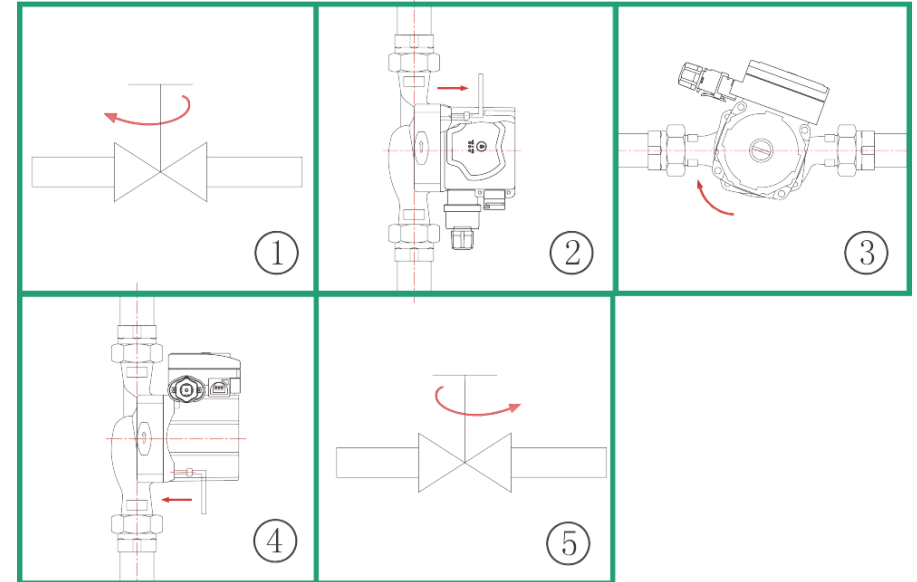

Warning



Pumping liquid may be high-temperature and high-pressure; therefore, the liquid in the system must be completely drained or the valves on both sides of motor pump must be closed before removing the socket head screws

3.4. Thermal Insulation of Motor Pump Body

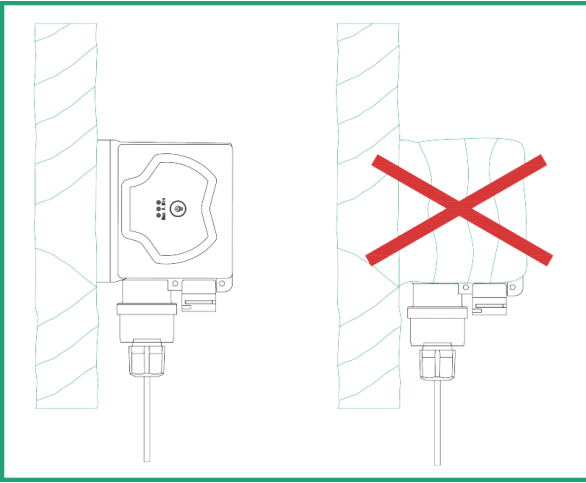

Note

Limiting the heat loss of motor pump body and pipeline

Motor pump body and pipeline should be thermally insulated to reduce their heat loss

Caution

Do not insulate or cover the junction box and control panel

4. Electrical Connection

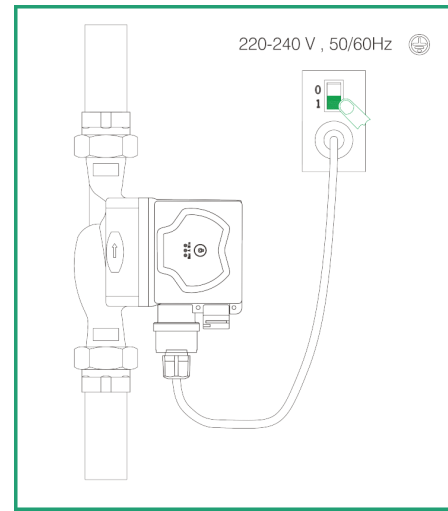
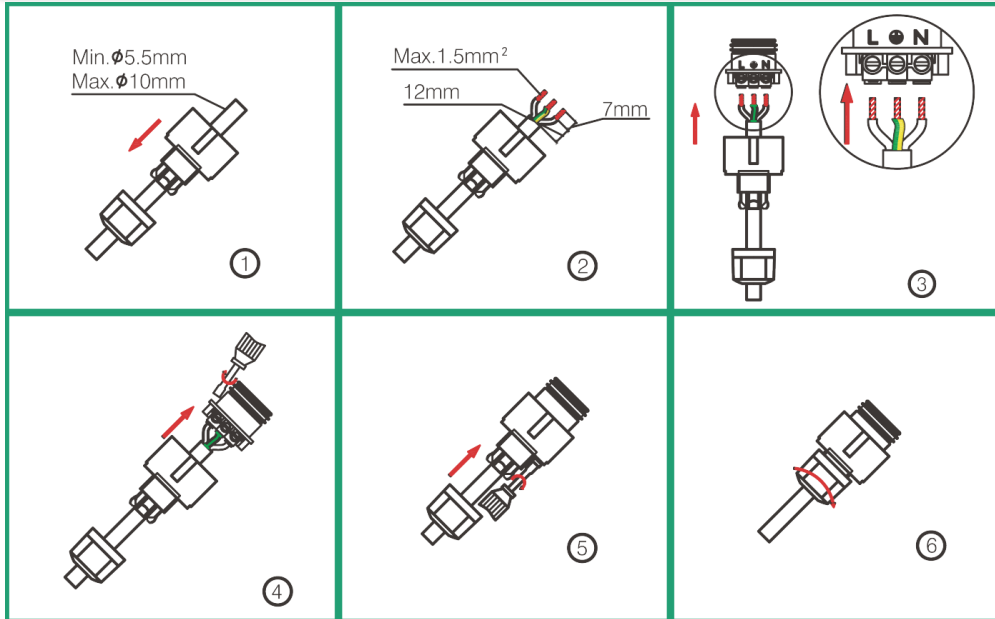

Electrical connection and protection shall comply with local codes and norms.



Warning

The motor pump must be earthed 

The motor pump must be connected to an external power switch, with 3mm minimum contact gap in both poles.

- APUMPHE series circulation motor pump needs no protection from external motor.
- Check if the supply voltage and frequency are the same as parameters indicated on the nameplate of the motor pump.
- Connect the motor pump and power supply with the plug supplied together with the pump.
- After the power is supplied, the indicator lamp on the control panel is ON

5. Control Panel

5.1. Controls on Control Panel

Position	Descriptions
1	Indication lamp area of three operation modes set by motor pump
2	Button for setting operation modes of the motor pump



5.2. Indication Lamp Area of Motor Pump Setting

APUMPHE series circulation motor pump has three settings which can be chosen with the button.

The motor pump settings are indicated with three different indication lamp areas.



Button Times	Indication Lamp Area	Descriptions
A 1 3	AUTO (Initial Setting)	Self-adaptive (AUTO)
	MAX	Constant speed curve, Velocity Max
	MIN	Constant speed curve, Velocity Min

5.3. Button for selecting motor pump settings

By pressing the button once at 2 seconds interval, the motor pump setting mode will change to the next in sequence.

A cycle is constituted of every three presses on the button. For details, please refer to Section 5.2